

A decorative graphic consisting of a series of blue dots of varying sizes, arranged in a curved path that starts from the bottom left and moves towards the top right, ending near the start of the main title.

# Technical Deep Dive: ICA Protocol and Acceleration

Jo Harder and Jason Maynard  
Worldwide Technical Readiness

# Agenda

ICA Functionality

ICA Monitoring and Optimization

ICA Acceleration

ICA Traffic Types



# ICA Functionality

# 7-Layer OSI Model

Layer	Protocol Data Unit	Description	Example
Presentation		Data conversion, compression, decompression, encryption, decryption	ICA
Transport	Segment	Segments and reassembles data into a data stream; end-to-end data transport services, port numbers	TCP, UDP
Network	Packet	Routes data packets	IP, Routers
Data Link	Frame	Contains Logical Layer Control (LLC-flow control and timing) and Media Access Control (MAC-physical address)	NICs, switches, VLANs
Physical	Bit	Sends and receives bits	Cabling, hubs, wireless

# ICA Communications

- Server receives on TCP port 1494; sends via dynamically allocated port number

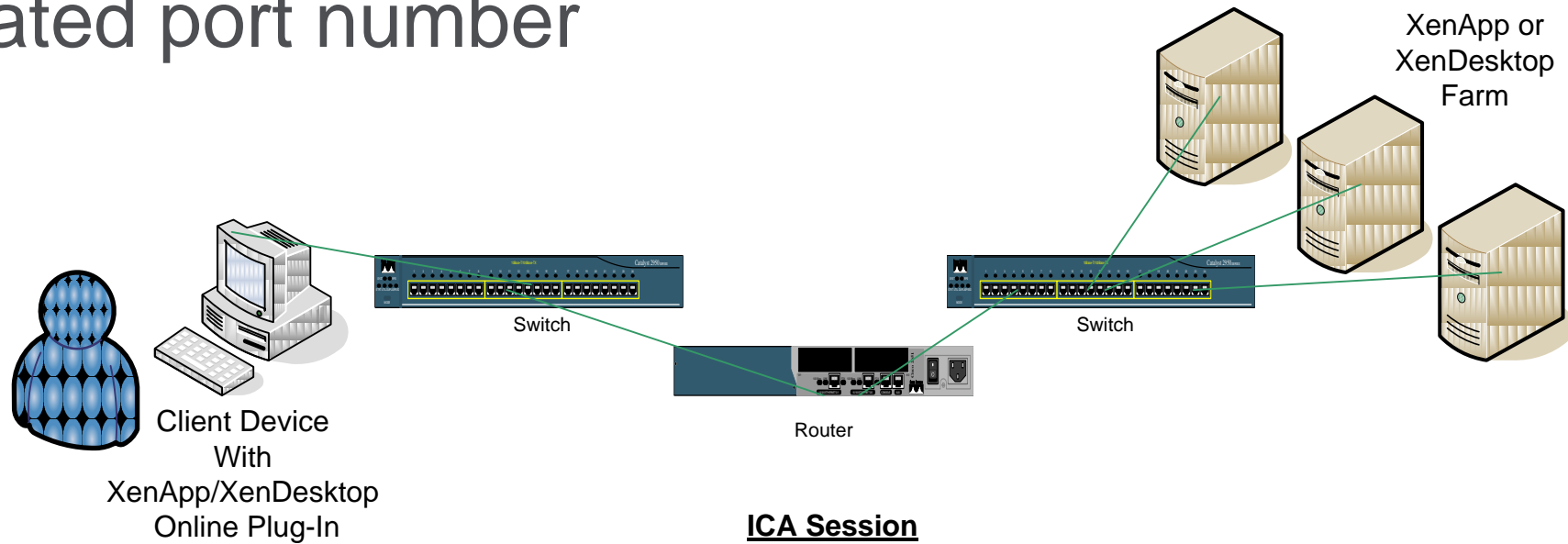

**ICA Session**  
--- >TCP 1494 (2598 if CGP used)  
< ---Dynamically Allocated Port

# Session Reliability

- Citrix Common Gateway Protocol (CGP)
- Session Reliability encapsulates ICA traffic through TCP 2598
  - Network traces will show port 2598, not 1494
- Data is buffered for specified period and connection is maintained

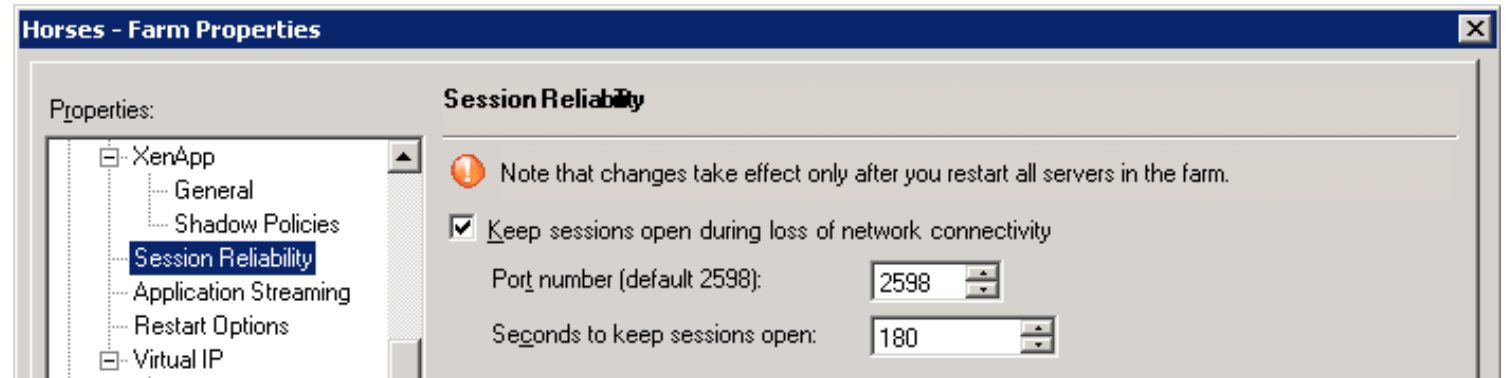

# ICA Data

- Frame size is small
- Port is 2598 (CGP)

The screenshot displays the Microsoft Network Monitor 3.3 interface. The main window shows a list of network frames. Frame 150 is selected, and its details are expanded in the 'Frame Details' pane. The 'TotalLength' field is circled in blue, and the 'SrcPort' field is also circled in blue. A red arrow points from the 'Frame size is small' text to the 'TotalLength' field, and another red arrow points from the 'Port is 2598 (CGP)' text to the 'SrcPort' field. The 'Hex Details' pane on the right shows the raw hex data of the frame.

Fra...	Time Offset	P.	Conv Id	Source	Destination	Protocol...	Description
149	9.412306		{TCP:2, IPv4:1}	10.15.34.221	10.11.4.25	TCP	TCP:Flags=...AP..., SrcPort=60825, DstPort=2598, PayloadLen=13, Seq=4069193
150	9.415407		{TCP:2, IPv4:1}	10.11.4.25	10.15.34.221	TCP	TCP:Flags=...AP..., SrcPort=2598, DstPort=60825, PayloadLen=6, Seq=78009099
151	9.420165		{TCP:2, IPv4:1}	10.15.34.221	10.11.4.25	TCP	TCP:Flags=...AP..., SrcPort=60825, DstPort=2598, PayloadLen=14, Seq=4069193
152	9.428273		{TCP:2, IPv4:1}	10.15.34.221	10.11.4.25	TCP	TCP:Flags=...AP..., SrcPort=60825, DstPort=2598, PayloadLen=14, Seq=4069193
153	9.431408		{TCP:2, IPv4:1}	10.11.4.25	10.15.34.221	TCP	TCP:Flags=...A..., SrcPort=2598, DstPort=60825, PayloadLen=0, Seq=78009099
154	9.436135		{TCP:2, IPv4:1}	10.15.34.221	10.11.4.25	TCP	TCP:Flags=...AP..., SrcPort=60825, DstPort=2598, PayloadLen=14, Seq=4069193
155	9.444165		{TCP:2, IPv4:1}	10.15.34.221	10.11.4.25	TCP	TCP:Flags=...AP..., SrcPort=60825, DstPort=2598, PayloadLen=14, Seq=4069193
156	9.447578		{TCP:2, IPv4:1}	10.11.4.25	10.15.34.221	TCP	TCP:Flags=...A..., SrcPort=2598, DstPort=60825, PayloadLen=0, Seq=78009099
157	9.452184		{TCP:2, IPv4:1}	10.15.34.221	10.11.4.25	TCP	TCP:Flags=...AP..., SrcPort=60825, DstPort=2598, PayloadLen=13, Seq=4069193
158	9.455580		{TCP:2, IPv4:1}	10.11.4.25	10.15.34.221	TCP	TCP:Flags=...AP..., SrcPort=2598, DstPort=60825, PayloadLen=6, Seq=78009099

Frame Details:

- Frame: Number = 150, Captured Frame Length = 60, MediaType = ETHERNET
- Ethernet: Etype = Internet IP (IPv4), DestinationAddress: [00-21-70-89-...]
- IPv4: Src = 10.11.4.25, Dest = 10.15.34.221, Next Protocol = TCP, PayloadLen = 6
- DifferentiatedServicesField: DSCP: 0, ECN: 0
- TotalLength: 46 (0x2E)
- Identification: 1335 (0x537)
- FragmentFlags: 16384 (0x4000)
- TimeToLive: 124 (0x7C)
- NextProtocol: TCP, 6 (0x6)
- Checksum: 48771 (0xBE83)
- SourceAddress: 10.11.4.25
- DestinationAddress: 10.15.34.221
- TCP: Flags=...AP..., SrcPort=2598, DstPort=60825, PayloadLen=6, Seq=78009099
- SrcPort: 2598
- DstPort: 60825

Hex Details:

```
0000 00 21 70 89 3E .!p[]>
0005 40 00 1A 30 28 @..0(
000A DC 40 08 00 45 Ū@..E
000F 00 00 2E 05 37 ....7
0014 40 00 7C 06 BE @.|.%.
0019 83 0A 0B 04 19 []....
001E 0A 0F 22 DD 0A .."Ý.
0023 26 ED 99 2E 7F &i[]..
0028 3E 6B F2 8A F7 >k[]÷
002D 2C 50 18 00 FF ,P..ý
0032 15 4A 00 00 05 .J...
0037 05 09 02 02 05 .....
003C
```

# ICA Discussion Points

- Bandwidth
- Compression and QoS
- Session sharing
- ICA Keepalives
- ICA virtual channels

# Bandwidth Allocation for ICA

- How much bandwidth is enough?
- It depends on:
  - Other network traffic
  - Application bandwidth requirements
  - Number of users
  - User behavior
  - And more!

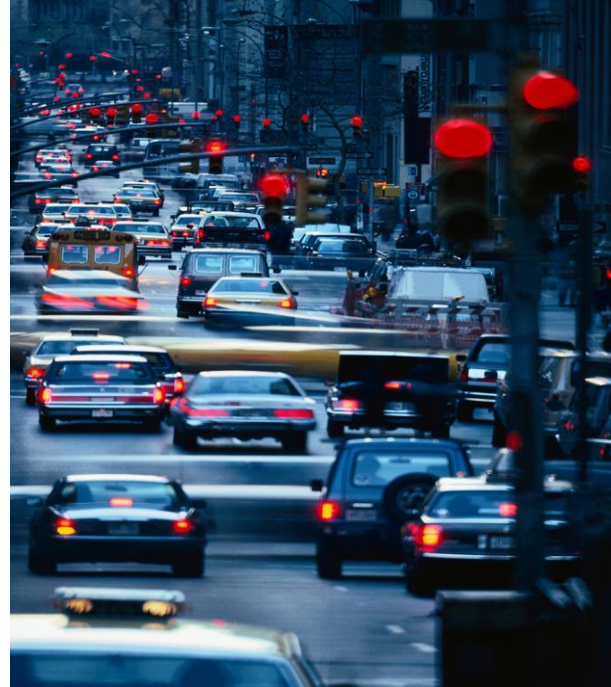

vs.

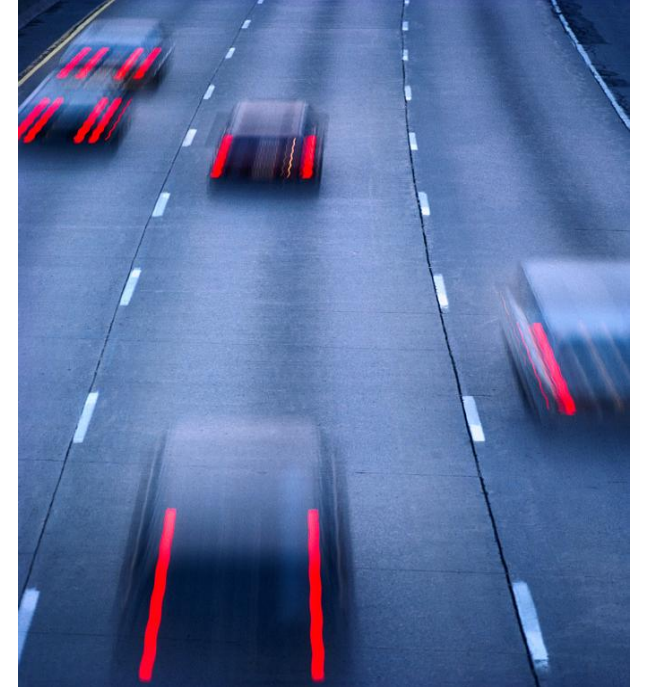

# Insufficient Bandwidth Causes . . .

- ICA sessions to drop
- Users experience choppy typing or screen paints
- Session Reliability to be invoked (if enabled)
  - User sees application but can't use it

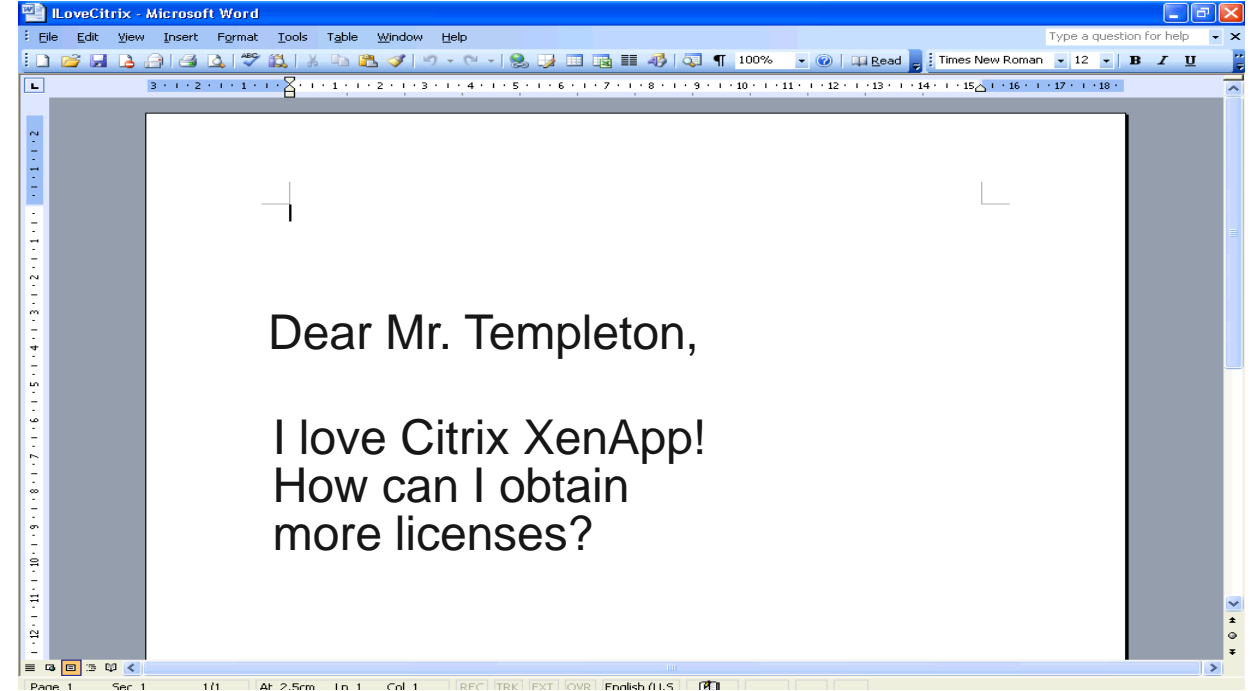

# ICA Compression

- Already highly compressed and optimized
- Automatically tunes itself to further compress when less bandwidth available
  - Single session bandwidth testing not valid!

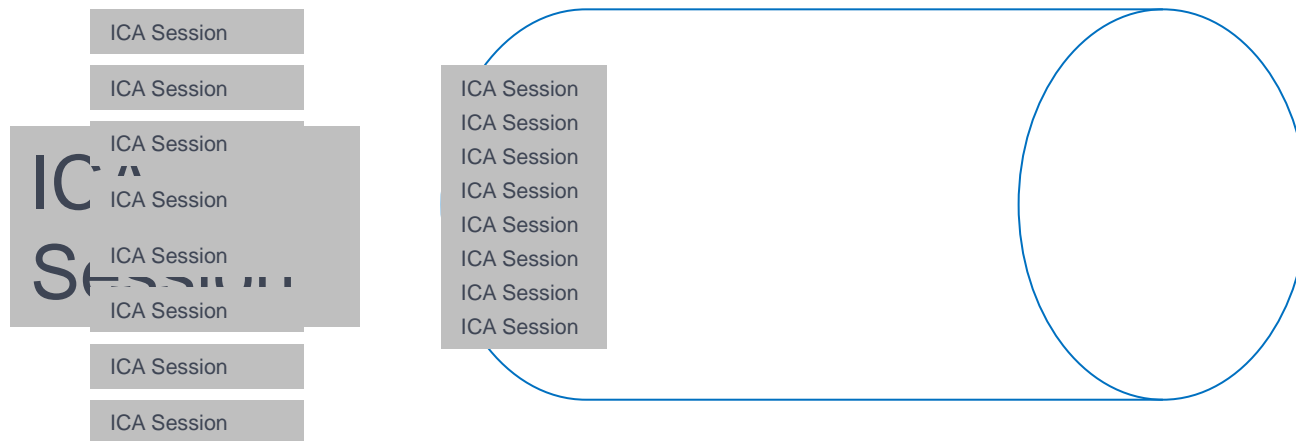

# Quality of Service (QoS)

- Prioritization
  - Less important data sacrificed if necessary
- Does not create any additional bandwidth
- Many different ways to configure
- ICA often prioritized
- Funnel size doesn't change!



# Session Sharing

- Multiple applications sharing the same ICA session
  - All apps must be on same server (streamed or installed)
  - Requires same or compatible display, audio, etc.
- Minimizes number of sessions per user
  - Not number of applications

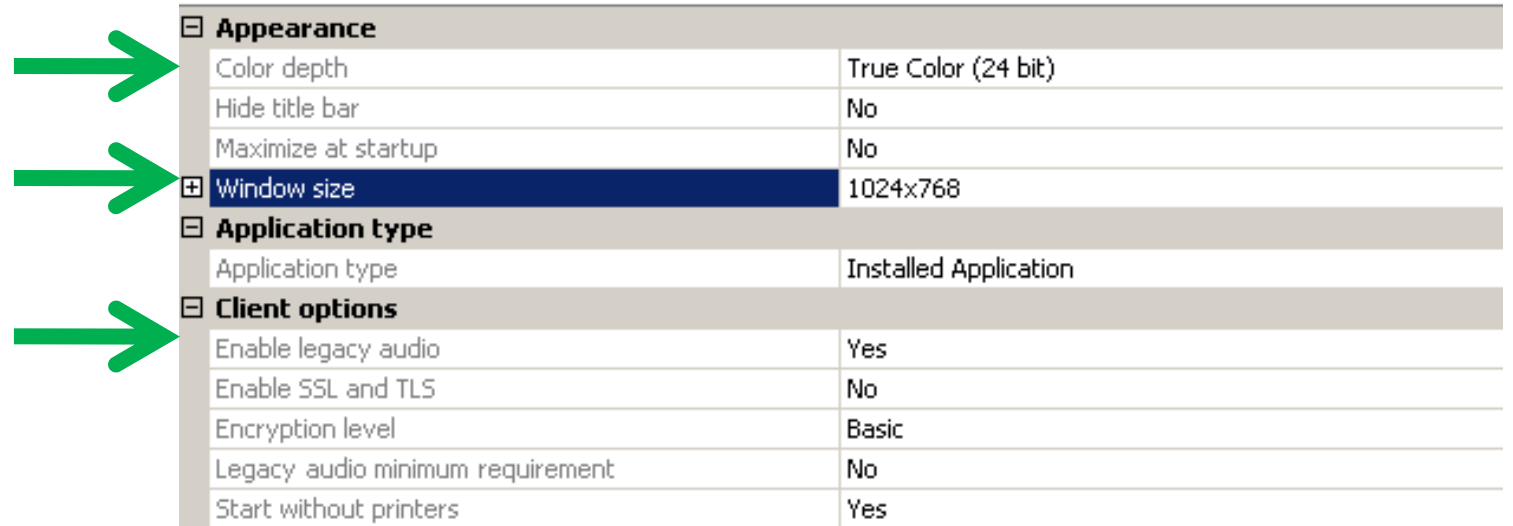

<b>Appearance</b>	
Color depth	True Color (24 bit)
Hide title bar	No
Maximize at startup	No
Window size	1024x768
<b>Application type</b>	
Application type	Installed Application
<b>Client options</b>	
Enable legacy audio	Yes
Enable SSL and TLS	No
Encryption level	Basic
Legacy audio minimum requirement	No
Start without printers	Yes

# Session Sharing Pre- and Post-HRP04

## HRP03 and earlier

- User has an ICA session open
- Requests another app on server
- Server load >10,000 (full)
- App accessed from another server

*Load balancing overrides session sharing*

## HRP04 and later

- User has an ICA session open
- Requests another app on server
- Server load >10,000 (full)
- App accessed from same server

*Session sharing overrides load balancing*

# ICA Keepalives vs. TCP Keepalives

- What is a keepalive?
  - Probe sent to client to make sure still there
- “Can you hear me now?” ← keepalive
  - “Yes.” ← Keepalive acknowledgement

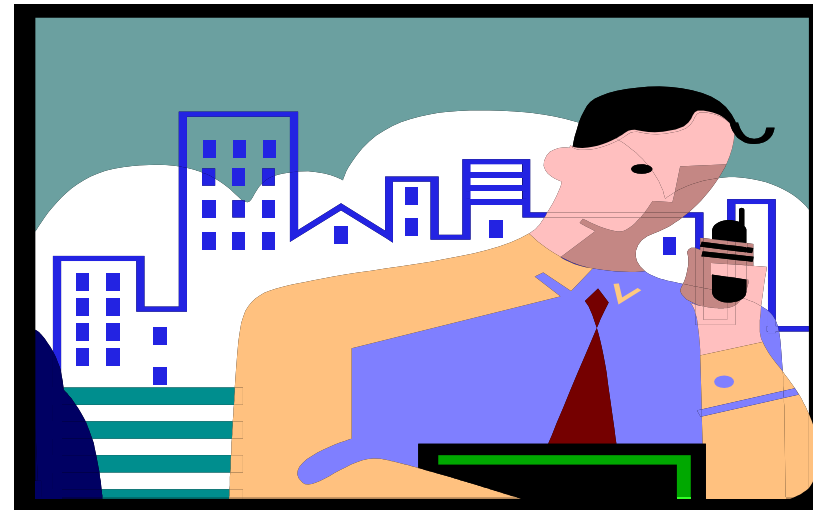

# ICA Keepalives

- Functions like TCP keepalives but at Layer 6
- Default is 1 minute
- Not enabled by default
  - Not needed with Session Reliability

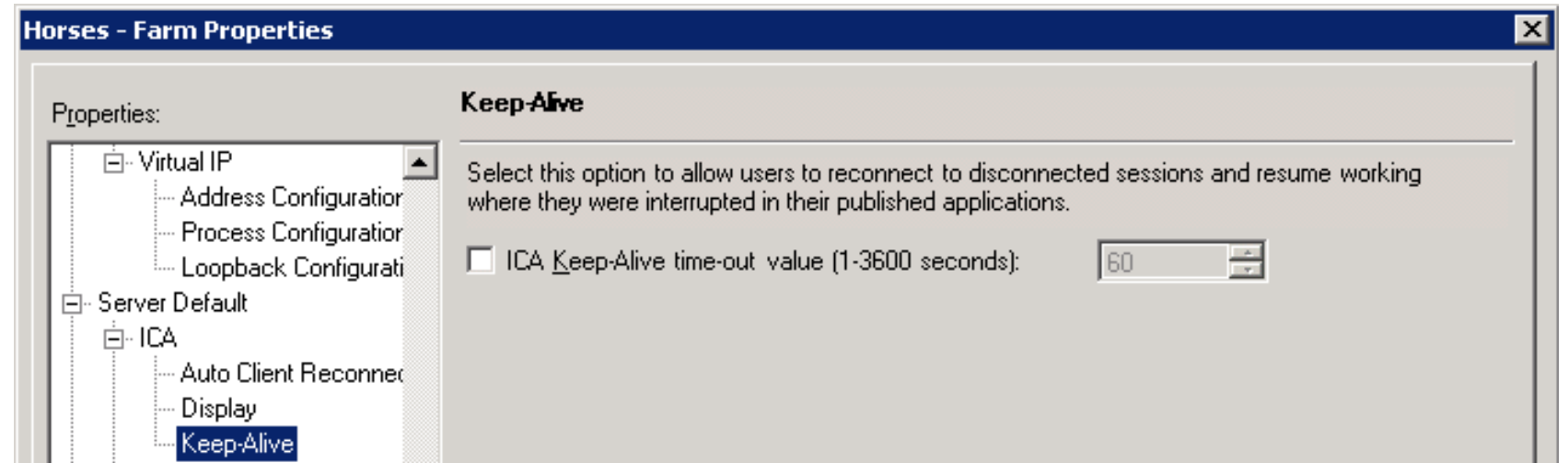

# ICA Virtual Channels

- ICA protocol comprised of 32 virtual channels
- Default priority can be modified but usually isn't

Priority	ICA Bits (decimal)	Sample Virtual Channels
High	00 (0)	Video, mouse, and keyboard screen updates
Medium	01 (1)	Program Neighborhood, clipboard, and audio mapping
Low	10 (2)	Client COM port mapping and client drive mapping
Background	11 (3)	Client printer mapping and OEM Channels



# ICA Monitoring and Optimization

# ICA Session Status

- Right click user session
- Shows errors and compression ratio  
Usually >2

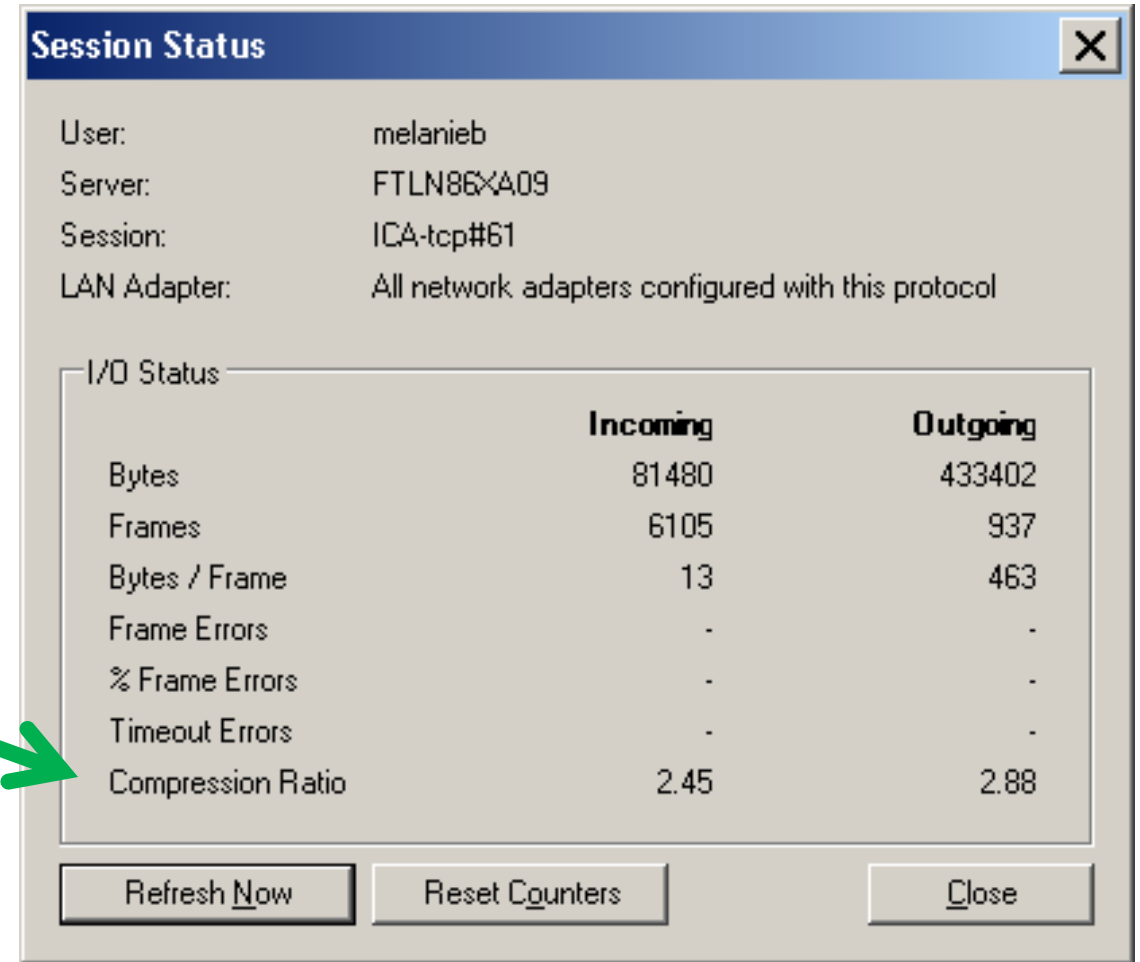

The screenshot shows a 'Session Status' dialog box with the following information:

User: melanieb  
Server: FTLN86XA09  
Session: ICA-tcp#61  
LAN Adapter: All network adapters configured with this protocol

I/O Status

	Incoming	Outgoing
Bytes	81480	433402
Frames	6105	937
Bytes / Frame	13	463
Frame Errors	-	-
% Frame Errors	-	-
Timeout Errors	-	-
Compression Ratio	2.45	2.88

Buttons: Refresh Now, Reset Counters, Close

A green arrow points from the text 'Usually >2' to the 'Compression Ratio' row in the table.

# Heavyweight Compression

- ICA can be further compressed by enabling heavyweight compression
- Provides ~20% additional compression

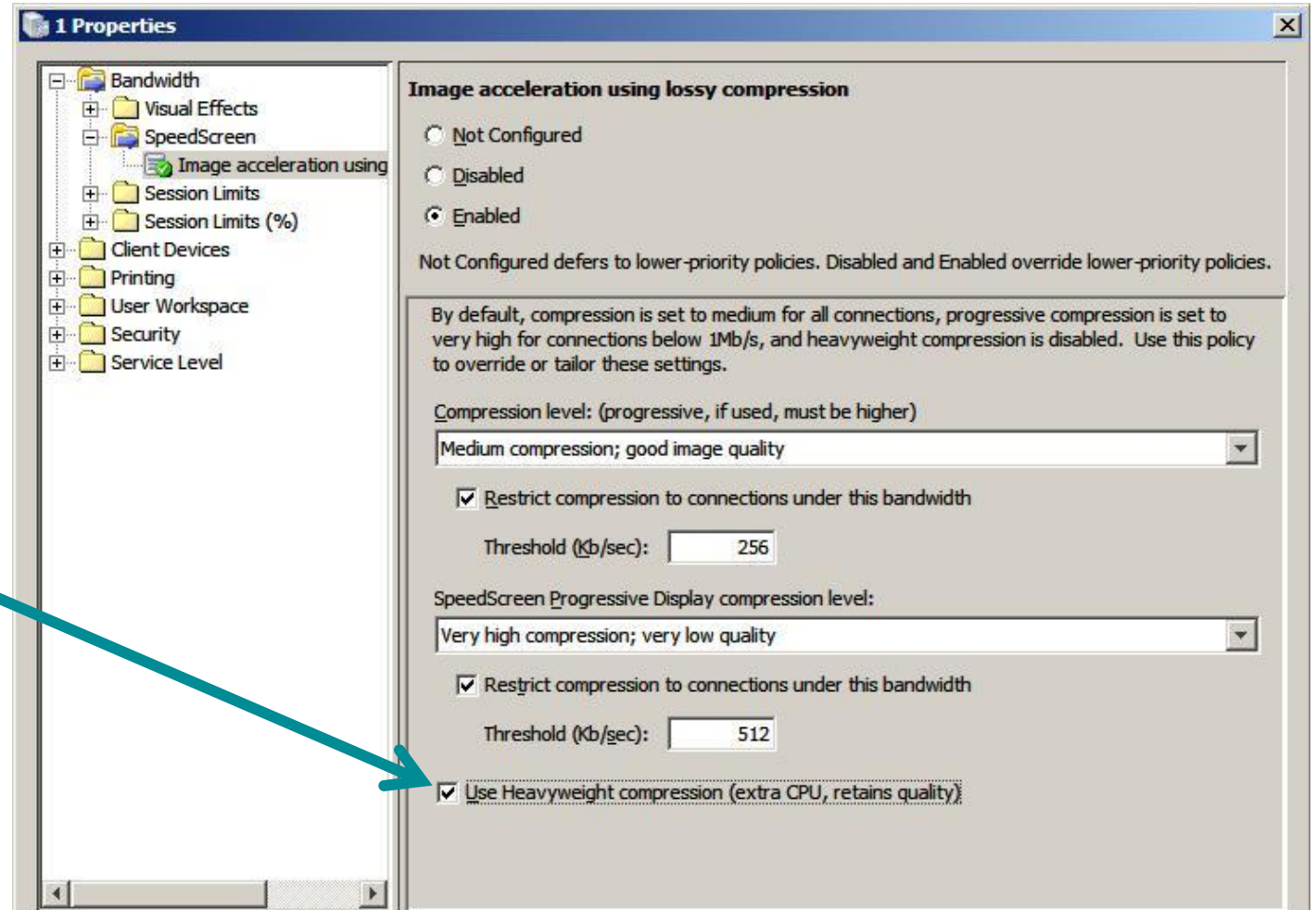

# ICA Channel Monitoring with EdgeSight

- ICA channel monitoring
  - Printer, drive and video
  - Session compression
  - Session line speed
  - Input and output audio
  - Input and output SpeedScreen data channel bandwidth
  - Input and output drive bandwidth
- Historical and real-time reporting
  - Highlights whether printing, file transfers or audio, video could be causing user experience issues

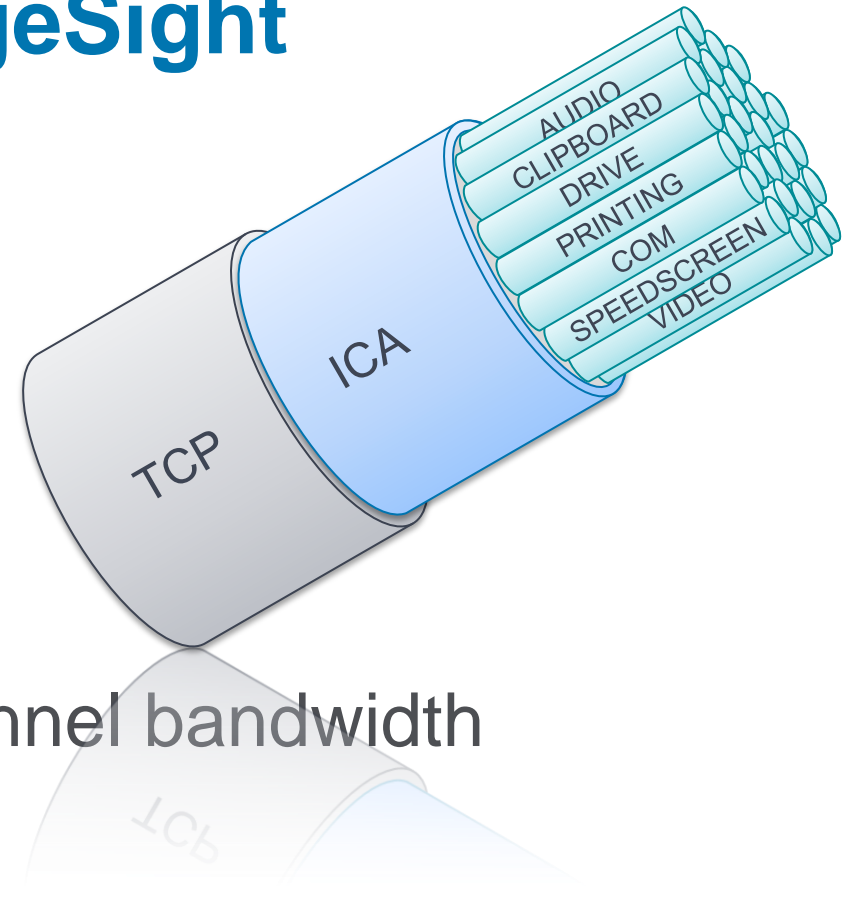

# Client Drive Mapping Virtual Channel

- Client drive mapping channel latency can be the most apparent to users
  - If not needed, disable drive access in Citrix policies or icaclient.adm GPO

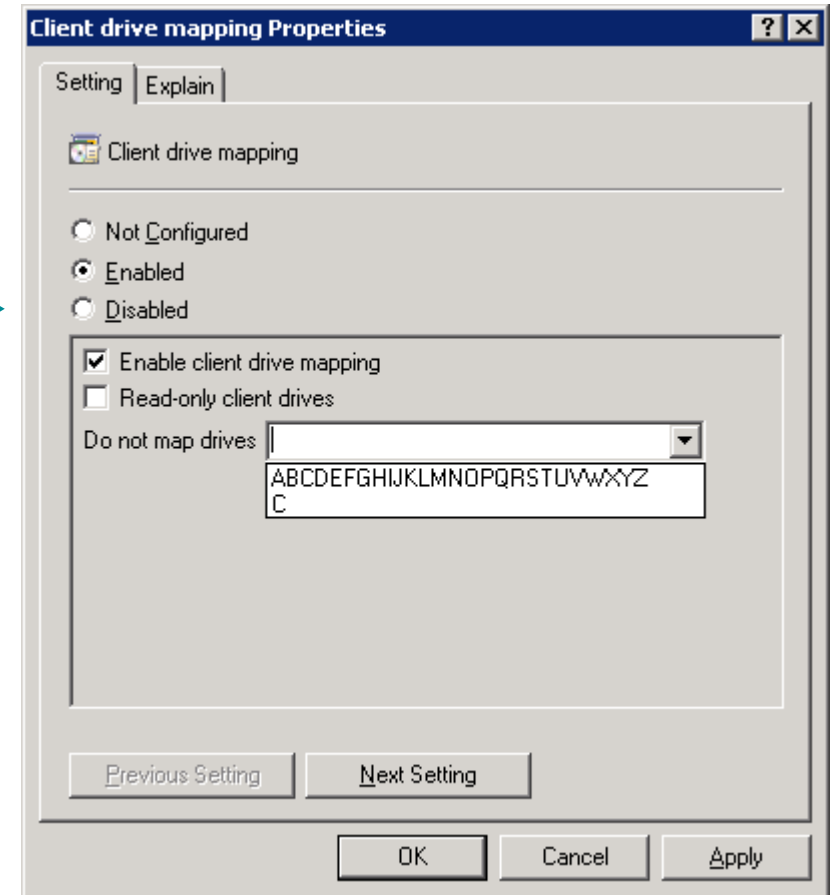
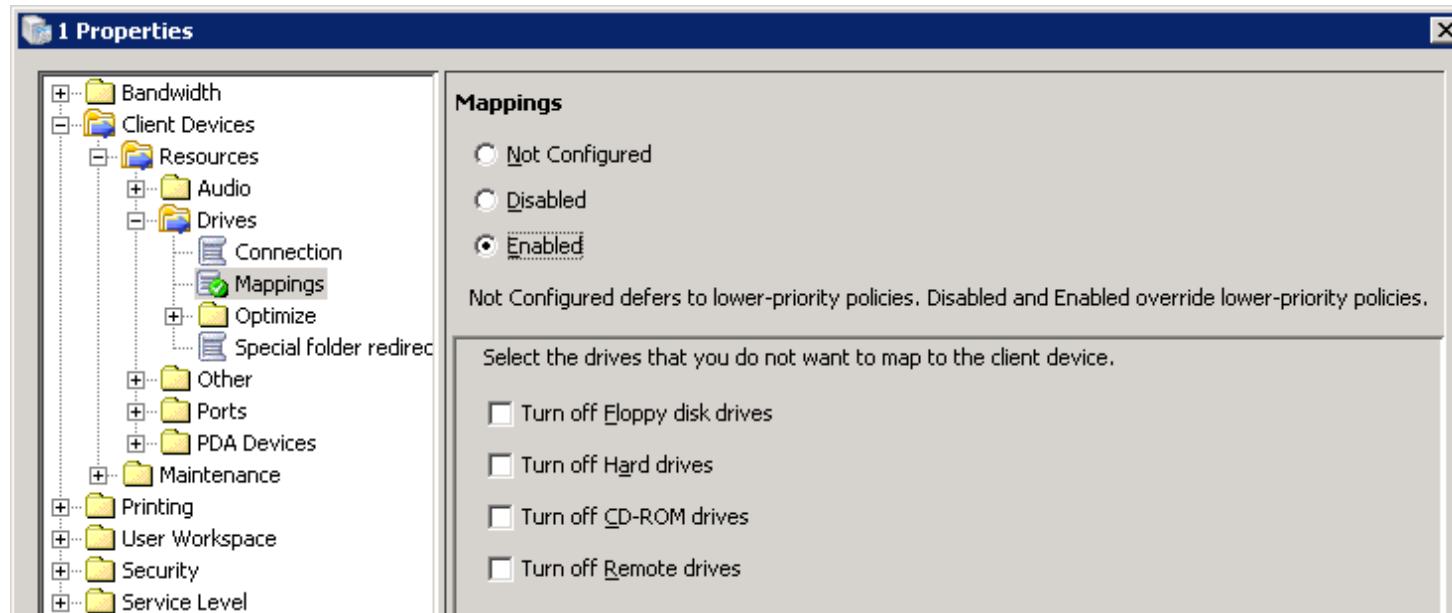

# Troubleshooting Virtual Channels with EdgeSight

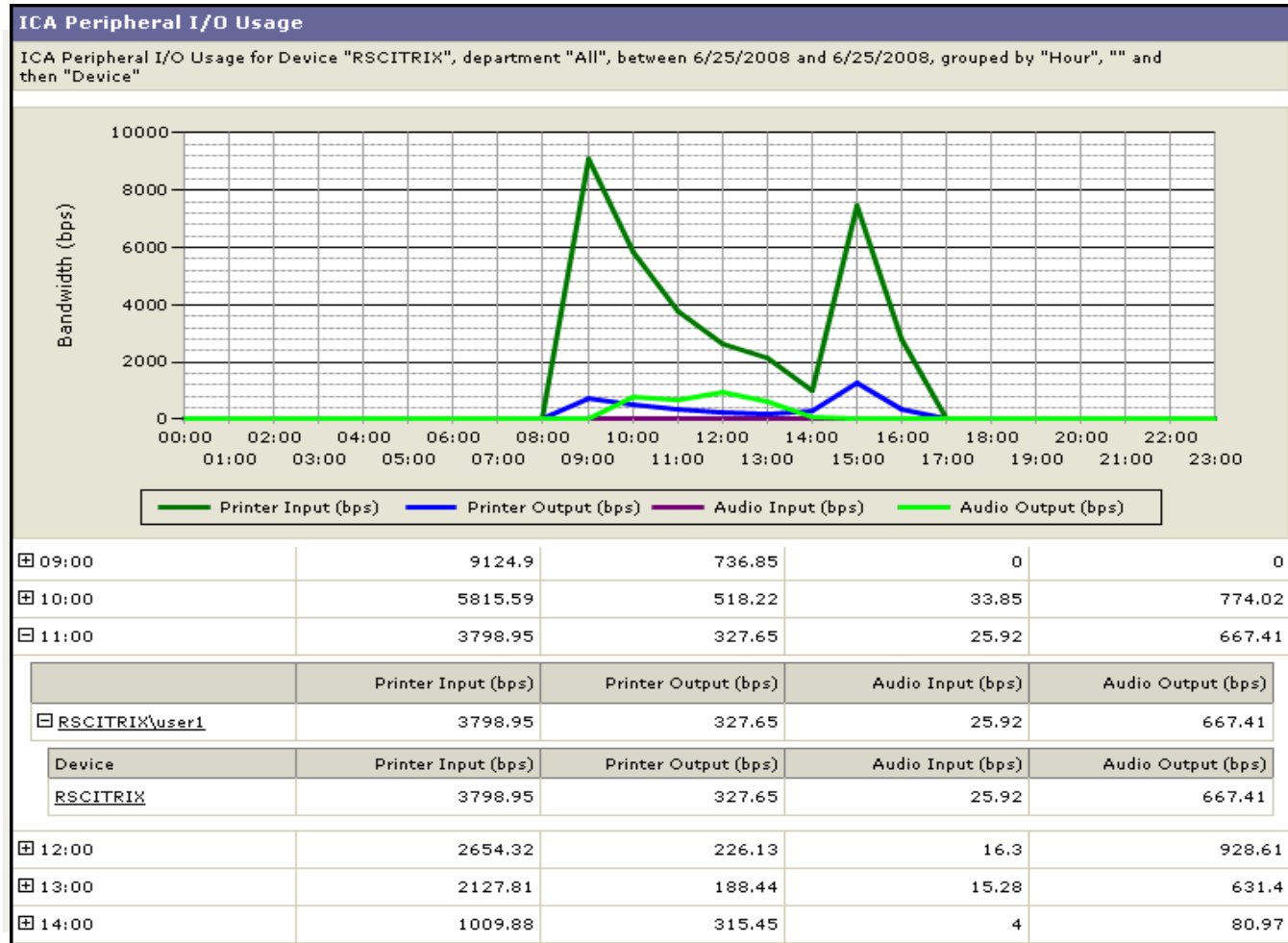

- User Troubleshooter
  - Active or disconnected sessions
  - Which channel is taking up the most bandwidth?
- Click on chart for detail
  - How much bandwidth is audio or video or printing using?
  - How is it impacting the session?

HDX

# ~~SpeedScreen~~ Impact

- Improves visual display or perception to user

Type	Benefit
Latency Reduction	Visual perception only
Browser Acceleration	JPEG image recompression & progressive drawing
Multimedia Acceleration	Improves how audio & video rendered
Flash Acceleration	Macromedia Flash quality reduced
Image Acceleration	Photographic quality reduced
Progressive Display	Dynamic drawings progressively improved



# ICA Acceleration

# Accelerating the ICA Protocol

- In conjunction with Branch Repeater, automatically accelerates ICA traffic across WAN links
- Benefits of WAN Optimization
  - Print time for PDF documents on 85% utilized WAN reduced up to 38%
  - See CTX120160 for more details



# ICA Acceleration for XenApp and XenDesktop

- Same functionality as XenApp for Windows Server 2003 HRP4 ported to next version of XenDesktop (2H09)
- Must also have latest version of Branch Repeater
- ICA Acceleration feature is automatically enabled on Branch Repeater

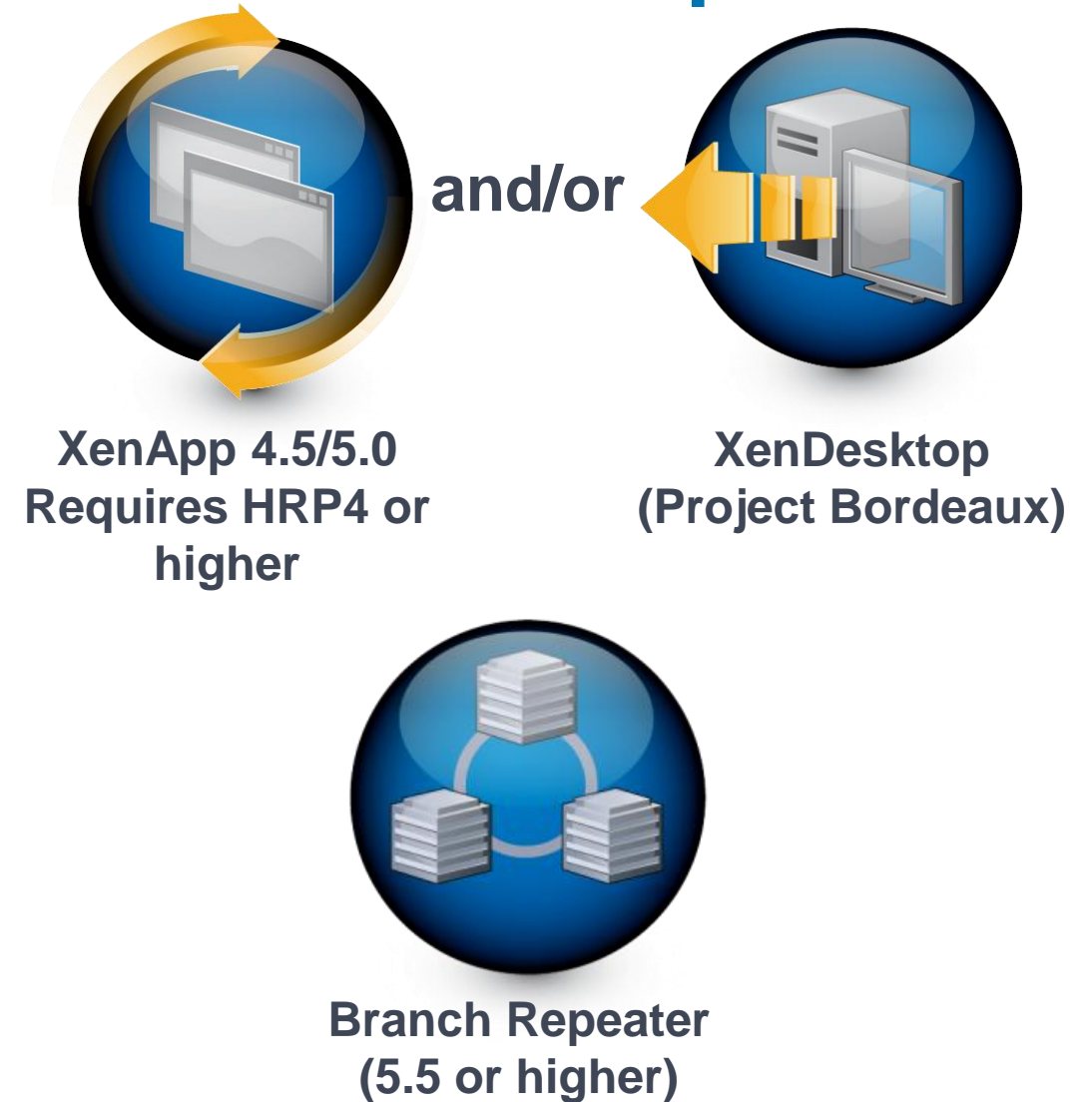

# ICA Protocol Challenges

- ICA is compressed and encrypted (by default)
- ICA multiplexes interactive and bulk traffic on a single connection
- ICA can multiplex multiple sessions on a single connection
- ICA uses extremely small block sizes
- ICA generates a lot of small packets (interactive)



# What is ICA “Acceleration”?

- Enhancements to Branch Repeater compression engine
- ICA encryption/decryption
- ICA parser
- ICA intra-session compression enhancements
- ICA cross-session compression



# Branch Repeater Encryption and Compression

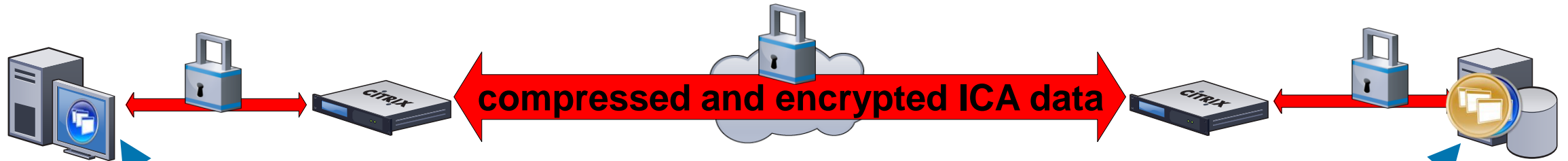

- Citrix XenApp Hosted Plug-in v11.0 for Windows or higher

- Windows Server 2003 only
- XenApp 4.5/5.0 HRP4 or higher is Branch Repeater-aware
- All XenApp editions supported
- During negotiation, XenApp compression is turned off

# Branch Repeater Encryption and Compression

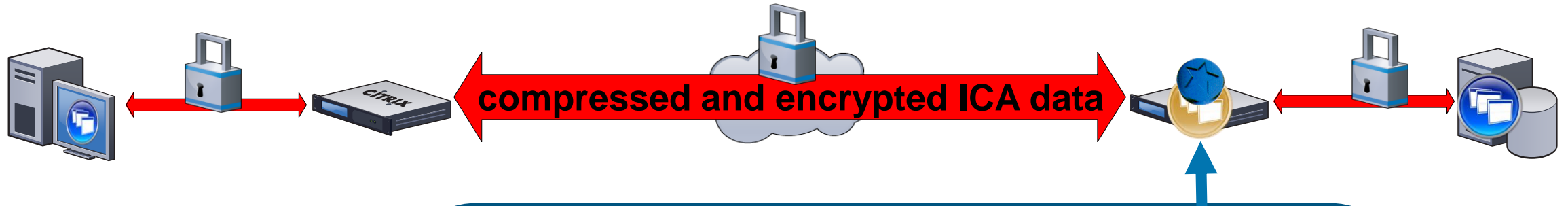

- ICA data is decrypted and parsed on the fly
  - Support for Basic through 128bit RC5; no SSL
  - Acceleration of >Basic encryption requires a registry change on the XenApp server
    - `HKEY_LOCAL_MACHINE\System\CurrentControlSet\Control\Citrix\WanScaler`
- Parser separates headers from payload and bulk from interactive
  - Display, print, file transfer, and multimedia

# Branch Repeater Encryption and Compression

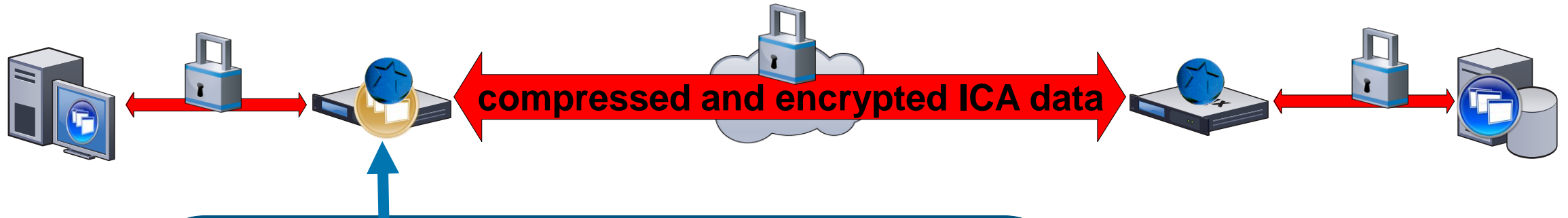

- ICA data is decrypted and then parsed
- Channel data is identified and compression history(s) accessed if needed
- Traffic is re-encrypted and sent to the client as expected

# Branch Repeater Encryption and Compression

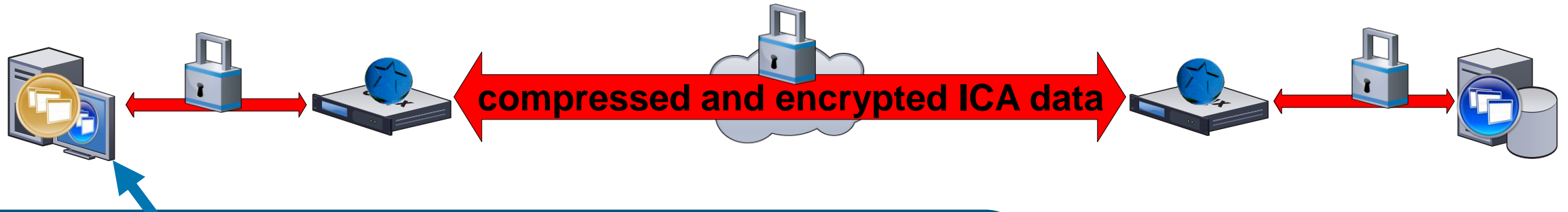

- XenApp plug-in “sees” the expected data stream
- Inline Branch Repeater(s) are transparent
- Identical process for client → server data

# Branch Repeater Encryption and Compression

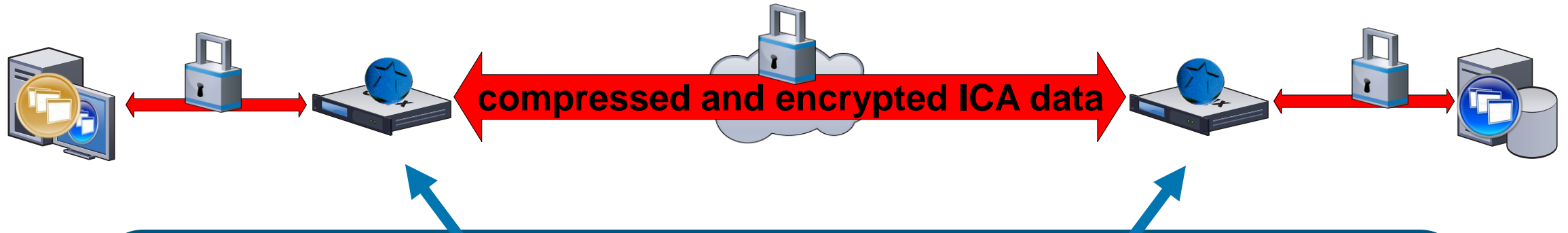

- Both devices are aware of the traffic in all accelerated connections
- Compressions histories get built up over time
- This process is automatic and transparent to the client and server

# Branch Repeater Encryption and Compression

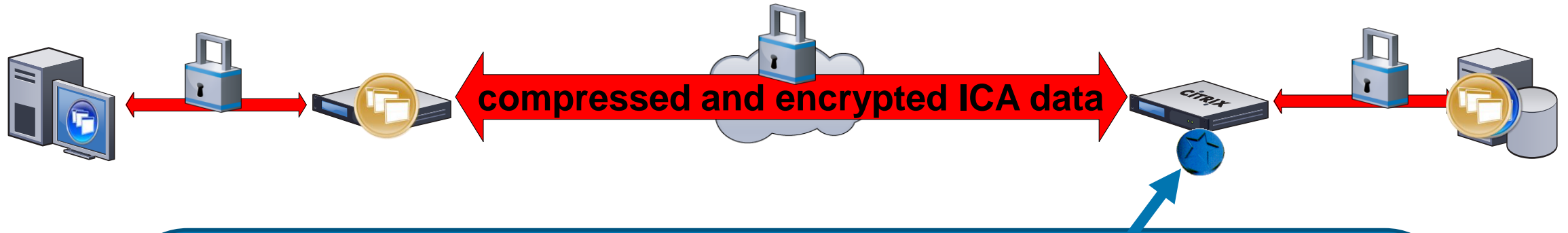

- Compression history matches are made against redundant data
- For matches, a small token is sent instead of the entire packet
- Token serves as a pointer to the client side history
- Client-side Branch Repeater uses the history to reassemble the data stream as expected by the client

# Branch Repeater Cross-Session Compression

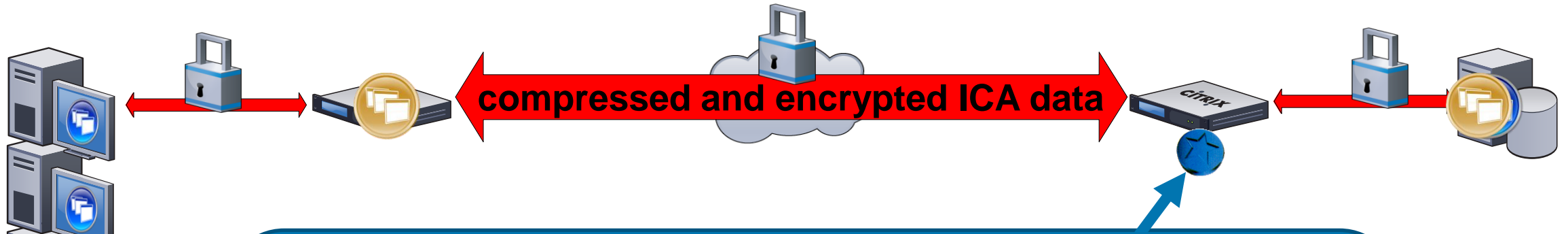

- Multiple XenApp users automatically leverage the history
- First user's session elements get "reused" by others
- No client reconfiguration is required
- Additional users require very little additional bandwidth



# ICA Traffic Types

# The ICA Stream – Printing Traffic

- Repeater compresses using disk (disk-based compression)
  - Minus the headers
  - Second pass of the same print job
    - ~70:1 compression
  - Small modifications followed by a print-job resend
    - Compresses well (35-40:1)
- Server limited throughput
  - Natural limits
  - Administrator defined limits
- Server-side print compressor is disabled



# The ICA Stream - File Access Traffic

- Repeater compresses using disk (DBC)
  - Minus the headers
  - Second pass give ~70:1
- Server has limited throughput
  - Remember: Natural limits of Disk I/O
  - Administrator defined limits through XenApp policies
  - Writes can be sync or async (faster).
  - XenApp servers with disk read and write buffering perform much faster
    - Battery-backed Write Cache



# The ICA Stream – Multimedia Traffic

- ICA has two types of multimedia rendering
  - Render on the server, send down bit maps (server-side rendering)
  - Send down .mpeg, render on client (client side codec)
- Sending multimedia stream data to client (client-side codec) compresses much better
  - Enable SpeedScreen Multimedia Acceleration via XenApp Policy
  - More info can be found in the ICA Acceleration Best Practices Module.
- Client render uses disk compression
  - Minus the headers. (headers do to the Nano matcher)
- MPEG data will only compress once the first chunk is in history
  - Compresses data on second+ pass only



# The ICA Stream – Display Traffic

- Applications (2 basic types)
  - Front buffer rendering – i.e. Word/Excel
  - Back buffer rendering – i.e. PowerPoint, PDF viewer,
    - Front buffer rendering issues graphics primitives (commands) such as “draw string”, “draw line”. i.e., Vector-based graphic elements
    - Back buffer rendering creates a bit-map locally, in a buffer and then blits the buffer contents to the screen. i.e., Bitmap-based graphic elements
- We compress front buffer rendering better than back buffer rendering
  - Less sensitivity to target (client) characteristics
- XenApp client/server display rendering changes
  - New version of Server/Client uses universal cache-handles (UCH)
  - UCH enable consistent object handles across multiple clients
  - **Only solution on the market with the ability for UCH!**



# Basic Application Types – Front Buffer

- Front buffer rendering issues graphics primitives such as draw string, draw line. etc.
  - Typically Word and Excel-like productivity applications
  - Form or document-based applications
- Citrix compresses front buffer rendering better than back buffer rendering
  - Less sensitivity to target (client) characteristics

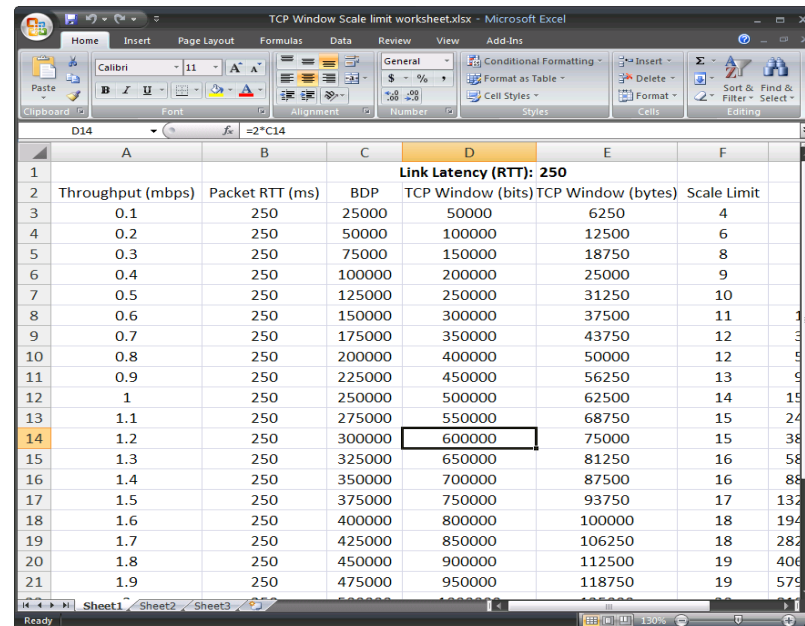

The screenshot shows a Microsoft Excel spreadsheet titled "TCP Window Scale limit worksheet.xlsx". The spreadsheet contains a table with the following data:

	A	B	C	D	E	F
1				Link Latency (RTT): 250		
2	Throughput (mbps)	Packet RTT (ms)	BDP	TCP Window (bits)	TCP Window (bytes)	Scale Limit
3	0.1	250	25000	50000	6250	4
4	0.2	250	50000	100000	12500	6
5	0.3	250	75000	150000	18750	8
6	0.4	250	100000	200000	25000	9
7	0.5	250	125000	250000	31250	10
8	0.6	250	150000	300000	37500	11
9	0.7	250	175000	350000	43750	12
10	0.8	250	200000	400000	50000	12
11	0.9	250	225000	450000	56250	13
12	1	250	250000	500000	62500	14
13	1.1	250	275000	550000	68750	15
14	1.2	250	300000	600000	75000	15
15	1.3	250	325000	650000	81250	16
16	1.4	250	350000	700000	87500	16
17	1.5	250	375000	750000	93750	17
18	1.6	250	400000	800000	100000	18
19	1.7	250	425000	850000	106250	18
20	1.8	250	450000	900000	112500	19
21	1.9	250	475000	950000	118750	19

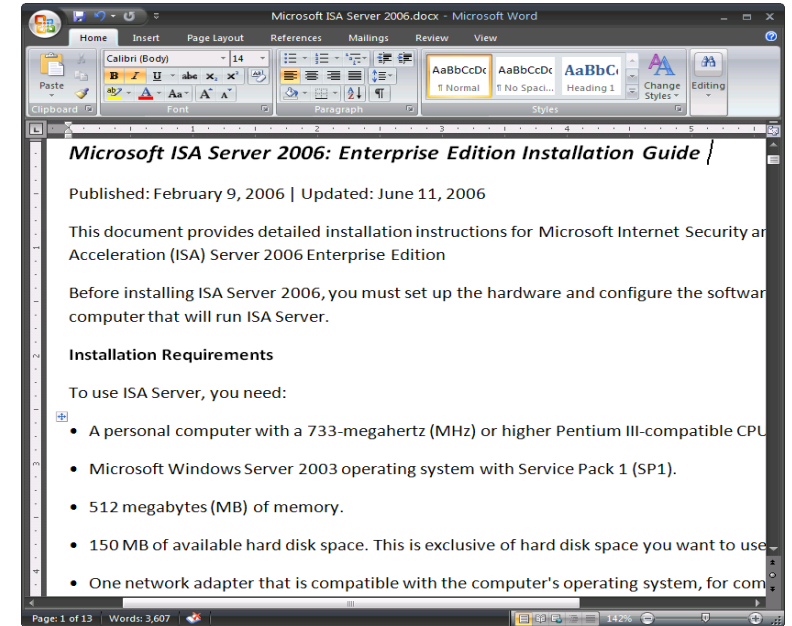

# Basic Application Types – Back Buffer

- Back buffer rendering creates a bit-map locally and then blits that to the screen along with image updates.
  - Photo editing, some CAD and 3D applications
  - PowerPoint, Adobe Acrobat, etc.
  - Greater sensitivity resolution and color depth settings

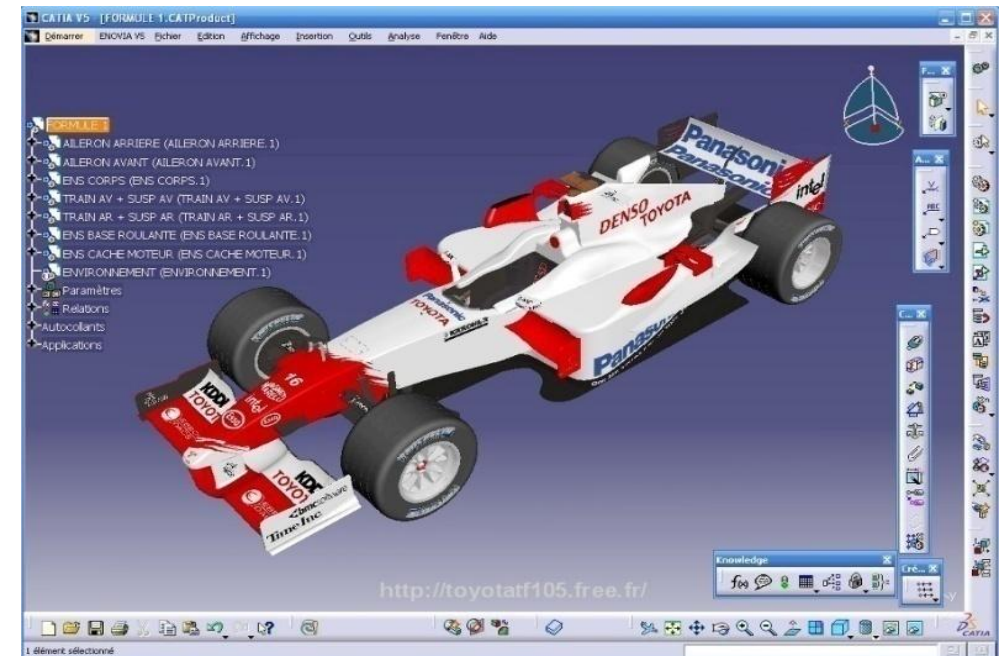

# Application Deployment Examples

## • Example #1

- The user's workspace is most of the window area
- Elements are drawn directly to the screen and are the same for all users (zoom levels, pages, etc.)

## POC Recommendations

- Excellent application choice
- Publish the app at the same color depth for all users
- If possible, choose apps deployed to similar client hardware (graphic/display capabilities)
- If applicable, disable any "skinned" or animated menus and controls

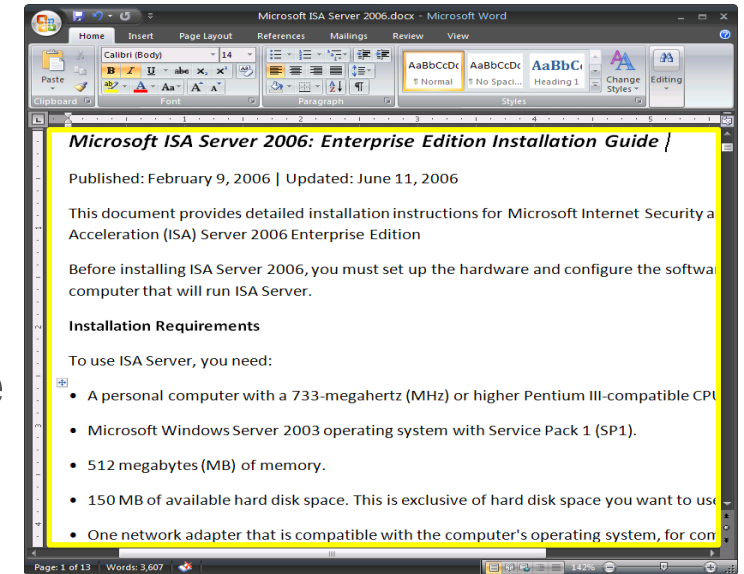

	A	B	C	D	E	F
1				<b>Link Latency (RTT): 250</b>		
2	Throughput (mbps)	Packet RTT (ms)	BDP	TCP Window (bits)	TCP Window (bytes)	Scale Limit
3	0.1	250	25000	50000	6250	4
4	0.2	250	50000	100000	12500	6
5	0.3	250	75000	150000	18750	8
6	0.4	250	100000	200000	25000	9
7	0.5	250	125000	250000	31250	10
8	0.6	250	150000	300000	37500	11
9	0.7	250	175000	350000	43750	12
10	0.8	250	200000	400000	50000	12
11	0.9	250	225000	450000	56250	13
12	1	250	250000	500000	62500	14
13	1.1	250	275000	550000	68750	15
14	1.2	250	300000	600000	75000	15
15	1.3	250	325000	650000	81250	16
16	1.4	250	350000	700000	87500	16
17	1.5	250	375000	750000	93750	17
18	1.6	250	400000	800000	100000	18
19	1.7	250	425000	850000	106250	18
20	1.8	250	450000	900000	112500	19
21	1.9	250	475000	950000	118750	19

# Application Deployment Examples

- Example #2

- The user's workspace is the image window →
- Variation in pan, zoom and user input can affect compression level: Less reusable (identical) screen area means lower compression ratio

## POC Recommendations

- Choose your apps carefully
- Publish the app at the same color depth for all users
- Publish the apps at a fixed resolution in XenApp (disable seamless windows)
  - <http://support.citrix.com/article/CTX112711>
- If possible, choose apps deployed to similar client hardware (graphic/display capabilities)
- This is why we do POC's!

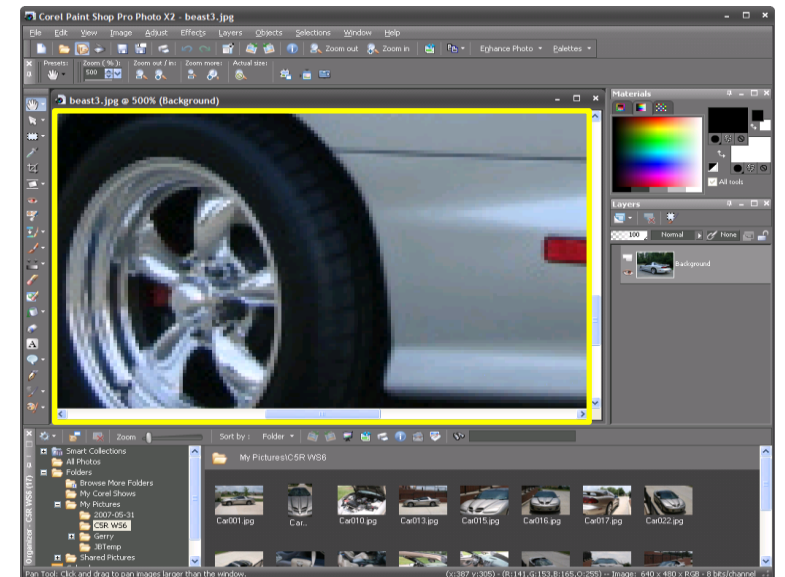

# Summary

- Understand ICA protocol functionality
  - How does ICA affect your environment?
- Monitor ICA traffic and optimize as appropriate
  - Can ICA traversal be improved on your network?
- If Branch Repeater deployed, leverage ICA acceleration
  - Which user groups and/or locations can benefit from increased productivity?
- Enhance the application delivery experience of your users
  - Can user satisfaction improve based on optimized ICA traffic?



# Secrets, Lies and VDI

Decode the myths and uncover the truth  
about desktop and application virtualization



- Hosted by Citrix featuring leading industry and product experts
- Sessions, live chat, networking lounge, collateral downloads and much more, this event is free and online
- Tuesday, October 20
- Register now at [www.citrix.com/citrixlive](http://www.citrix.com/citrixlive)

**CITRIX<sup>®</sup>**